

Cartridge-Filtereinsätze

Ausführung ohne O-Ring

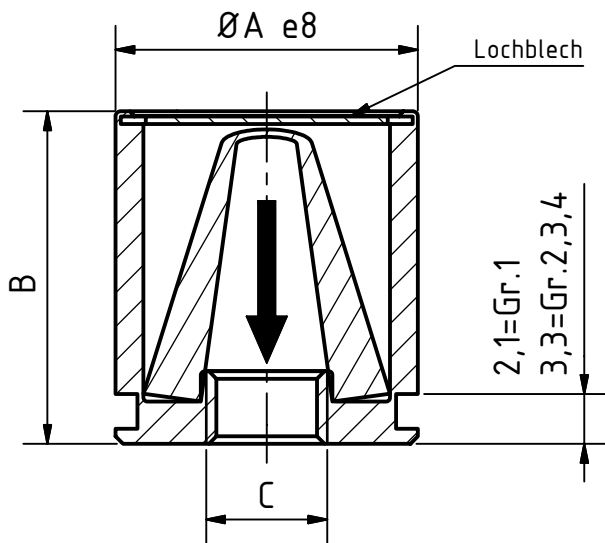

Ausführung mit O-Ring

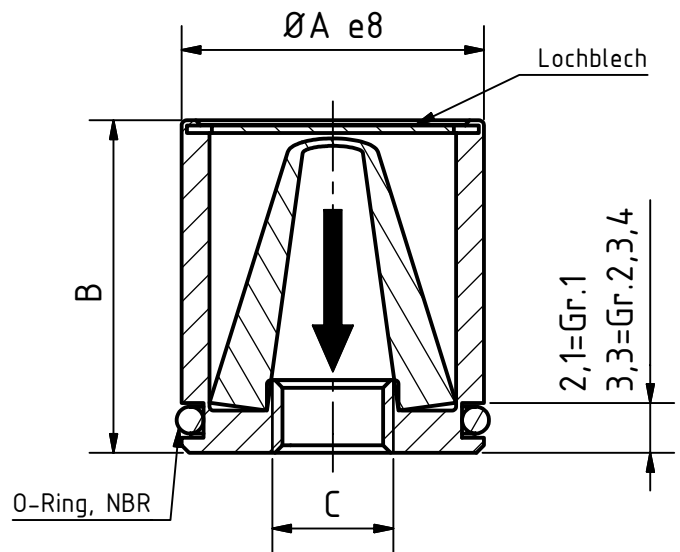

Werkstoffe: Edelstahl

Filtermaterial: Drahtgewebe und Metallfaservlies

für Ø A erforderlicher Bohrungs-Ø H7
max. Δp 20 bar

Größe	Bestell-Nr.	Feinheit in µm	Ø A	B	C	Größe	Bestell-Nr.	Feinheit in µm	Ø A	B	C
1	41017	5	17,0	20,7	M6	1	42017	5	17,0	20,7	M6
	41005	10					42005	10			
	41001	25					42001	25			
	41002	40					42002	40			
	41003	60					42003	60			
	41004	100					42004	100			
2	41018	5	20,0	22,0	M8	2	42018	5	20,0	22,0	M8
	41016	10					42016	10			
	41011	25					42011	25			
	41012	40					42012	40			
	41013	60					42013	60			
	41014	100					42014	100			
3	41019	5	25,0	26,0	M10	3	42019	5	25,0	26,0	M10
	41020	10					42020	10			
	41021	25					42021	25			
	41022	40					42022	40			
	41023	60					42023	60			
	41024	100					42024	100			
4	41029	5	30,0	30,0	M14	4	42029	5	30,0	30,0	M14
	41030	10					42030	10			
	41031	25					42031	25			
	41032	40					42032	40			
	41033	60					42033	60			
	41034	100					42034	100			

microfilter gmbh

Kirschenwasen 12
D-74670 Forchtenberg
Tel.: + 49 / 7948 / 9417-0
Fax.: + 49 / 7948 / 9417-290
Internet: www.microfilter.de

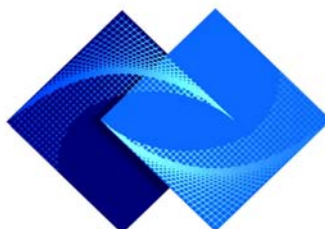

Freimaßtoleranzen
nach DIN ISO
2768-m

Technische und Maßliche
Änderungen vorbehalten